

ESCALA/SCALE 1:100

ESCALA/SCALE 1:40

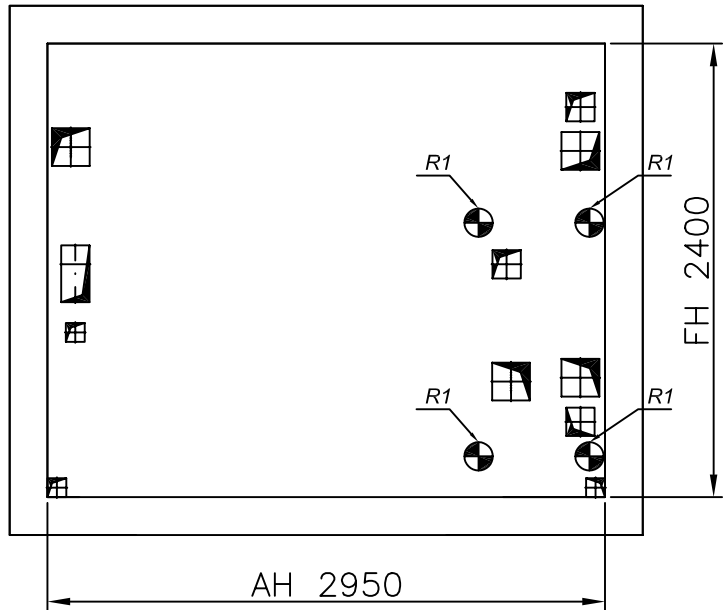

ESCALA/SCALE 1:40

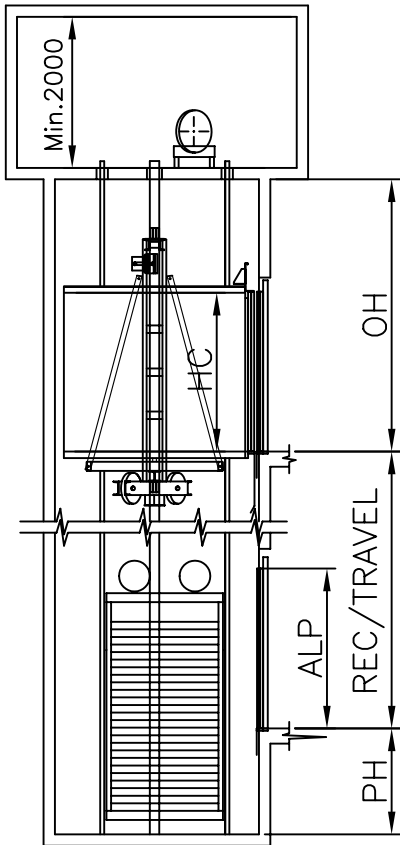
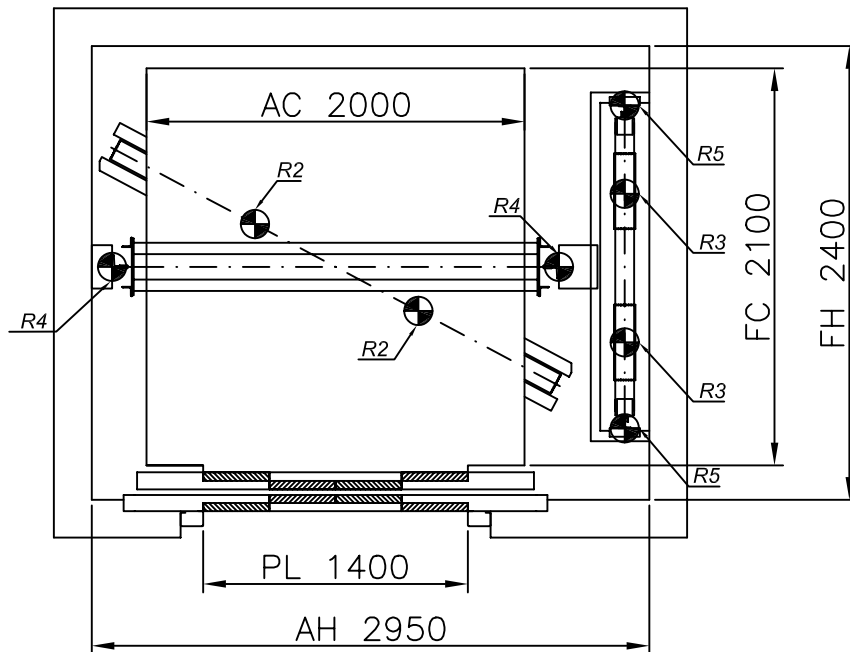

**ACCIONES SOBRE EL HUECO**

**MP2610 GO! "C"**

R1	CARGA SOBRE SOBRESLOSA / SLAB LOAD	51188 N
R2	CARGA EN PUFFER CAB / CAR BUFFER LOAD	74180 N
R3	CARGA EN PUFFER CPSO / CTW BUFFER LOAD	54540 N
R4	CARGA EN GUÍA CAB / CAR GUIDE LOAD	42340 N
R5	CARGA EN GUÍA CPSO / CTW GUIDE LOAD	1650 N
	REACCION DE GUIAS Sx / GUIDES REACTIONS Sx	1470 N
	REACCION DE GUIAS Sy / GUIDES REACTIONS Sy	2800 N

2000 Kg	1 m/s	
26 P.	GO!	
FOSO/PIT	HUIDA/OVERHEAD	
1400	3600	
		16 Kw

ESCALA/SCALE 1:100

ESCALA/SCALE 1:40

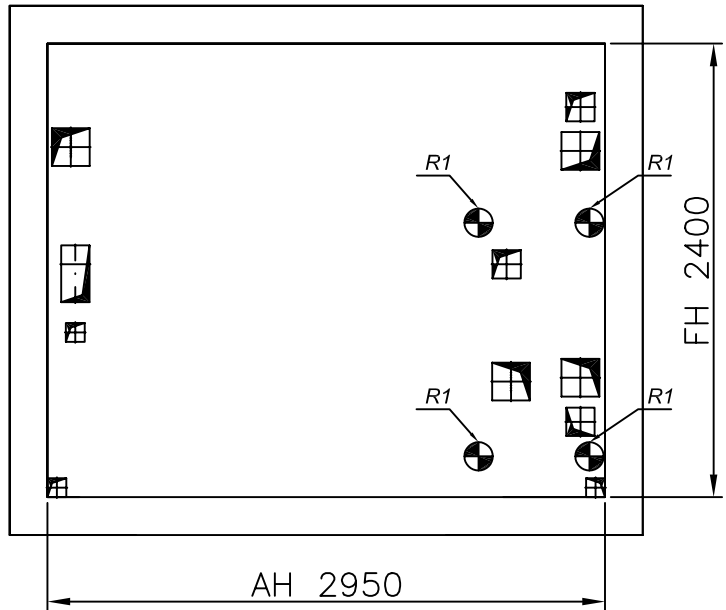
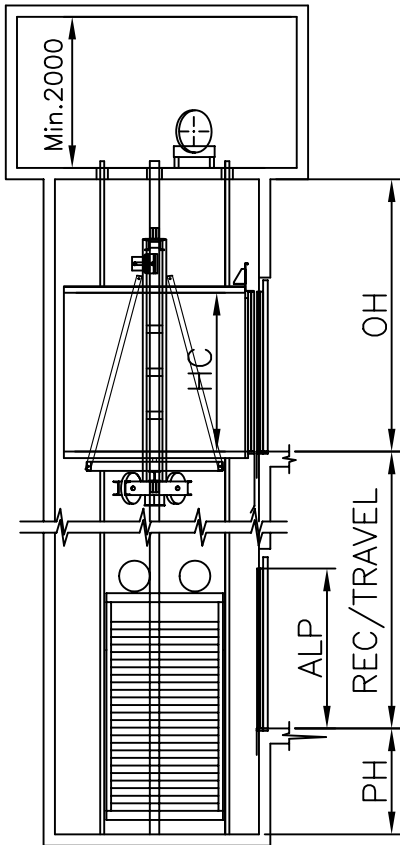

ESCALA/SCALE 1:40

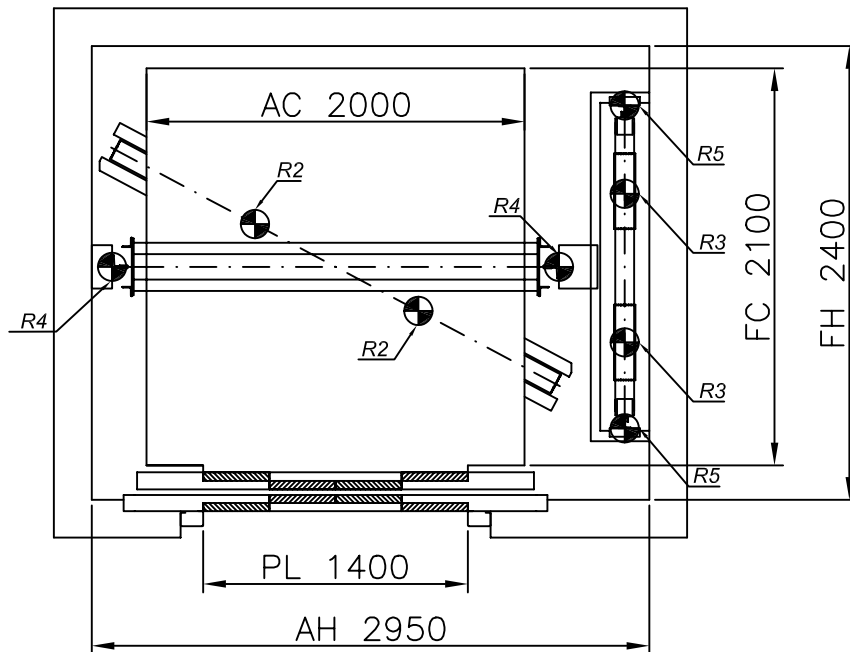

**ACCIONES SOBRE EL HUECO**

**MP2616 GO! "C"**

R1	CARGA SOBRE SOBRES LOSA / SLAB LOAD	51188 N
R2	CARGA EN PUFFER CAB / CAR BUFFER LOAD	74180 N
R3	CARGA EN PUFFER CPSO / CTW BUFFER LOAD	54540 N
R4	CARGA EN GUÍA CAB / CAR GUIDE LOAD	42340 N
R5	CARGA EN GUÍA CPSO / CTW GUIDE LOAD	1650 N
	REACCION DE GUIAS Sx / GUIDES REACTIONS Sx	1470 N
	REACCION DE GUIAS Sy / GUIDES REACTIONS Sy	2800 N

2000 Kg	1.6 m/s
26 P.	GO!
FOSO/PIT	HUIDA/OVERHEAD
1500	3700



26 Kw